

# BIRKDALE TOWER BOLT

PRODUCT CODE PREFIXES: 100 & 510

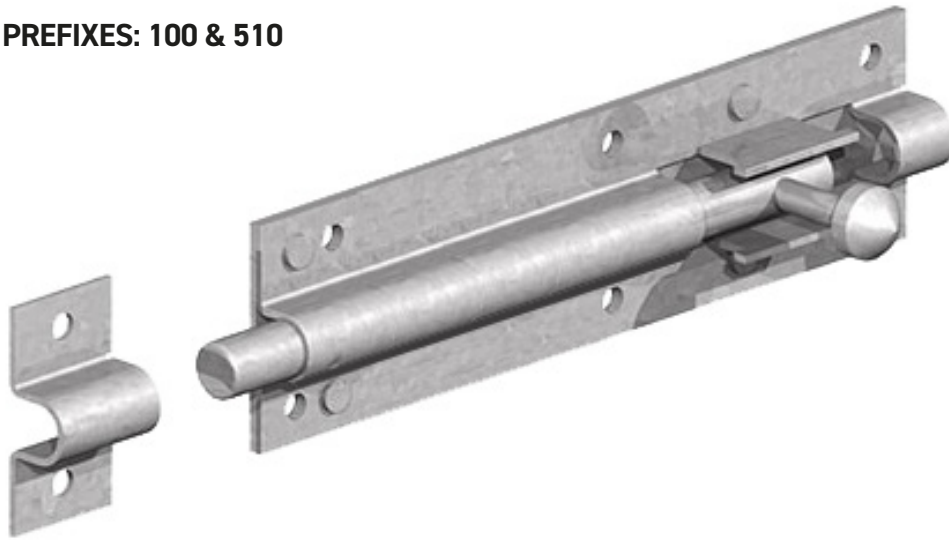

## DESCRIPTION

The Tower bolt is a slide bolt that is fixed to the rear of a gate or door holding in the closed position. It is suitable for interior and exterior use.

The GateMate pre-packed range is supplied complete with exterior type fixings which compliment the finish of the tower bolt

## CONSTRUCTION

Constructed from mild steel.

**GALVANISED:** Coated in accordance with BS/EN ISO 1461:2009. The average coating thickness is 45 microns. If the product is fitted correctly and the surface finish is not damaged the service life of 15 years can be expected. All items are coated in accordance with BS-13438.

**BLACK POLYESTER COATING:** Polyester powder coating is a type of coating that is applied as a free-flowing dry powder. The powder is a thermoset polymer, which is used to create a hard finish that is tougher than conventional paint. Powder coating is mainly used for the coating and protection of metals. Polyester Powder Coatings offer durable decorative finishes in a wide range of colours, textures, and gloss

levels. They are formulated to provide maximum corrosion resistance, colour stability and gloss retention. They are suitable for interior and exterior use and entirely T.G.I.C free (triglycidyl isocyanate crosslinkers). All items are coated in accordance with BS-13438.

BRIGHT ZINC PLATING (BZP) is an electro plating zinc process. BZP products give a good level of corrosion resistance. The bright zinc coating is coated in accordance with ASTM B633-19. The average zinc coating thickness is 12 microns.

## FINISH

Galvanised  
(Hot Dip)

Epoxy  
Black

BZP

**Tower Bolt**

FINISH	SIZE INS (MM)	MIN. ORDER QTY	OUTER CARTON QTY	CODE
Galvanised	3 (75)	10	100	100 0751
Galvanised	4 (100)	10	100	100 1001
Galvanised	6 (150)	10	50	100 1501
Galvanised	8 (200)	10	40	100 2001
Galvanised	10 (250)	10	40	100 2501
BZP	3 (75)	10	100	100 0752
BZP	4 (100)	10	100	100 1002
BZP	6 (150)	10	50	100 1502
BZP	8 (200)	10	50	100 2002
Epoxy Black	3 (75)	10	100	100 0753
Epoxy Black	4 (100)	10	100	100 1003
Epoxy Black	6 (150)	10	50	100 1503
Epoxy Black	8 (200)	10	50	100 2003
Epoxy Black	10 (250)	10	50	100 2503

**GATEMATE® Tower Bolt**

FINISH	SIZE INS (MM)	MIN. ORDER QTY	CODE
Galvanised	3 (75)	5	510 0751
Galvanised	4 (100)	5	510 1001
Galvanised	6 (150)	5	510 1501
Galvanised	8 (200)	5	510 2001
Galvanised	10 (250)	5	510 2501
BZP	4 (100)	5	510 1002
BZP	6 (150)	5	510 1502
BZP	8 (200)	5	510 2002
Epoxy Black	3 (75)	5	510 0753
Epoxy Black	4 (100)	5	510 1003
Epoxy Black	6 (150)	5	510 1503
Epoxy Black	8 (200)	5	510 2003
Epoxy Black	10 (250)	5	510 2503

