

MATERIAL: MILD STEEL  
 SURFACE FINISH: HOT DIP GALVANIZE  
 144 186 1 RIGHT HAND PADLOCK PROTECTOR IS  
 OPPOSITE TO 144 185 1 LEFT HAND PADLOCK PROTECTOR

7	144 815 1-7	SECURE PLATE	1
6	144 815 1-6	PIN	1
5	144 815 1-5	SHEILD	1
4	144 815 1-4	MALE HINGE	1
3	144 815 1-3	FEMALE HINGE	1
2	144 815 1-2	STRIKER PAD	1
1	144 815 1-1	STRIKER BACK PLATE	1
ITEM	PART NUMBER	MANE	QTY

INITIAL ISSUE	DRN	<b>BIRKDALE</b> Superior Gate and Fencing Accessories	
	DATE		
	CH'D	TITLE	
	DATE	LEFT HAND PADLOCK PROTECTOR	
	APP'D	DRAWING No. 144 185 1	A3
1	DATE	WGT	SHEET OF SHEETS

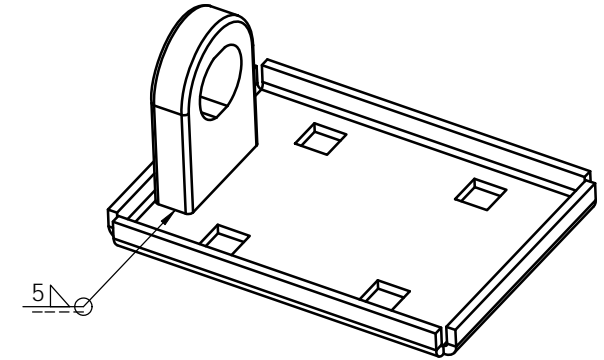
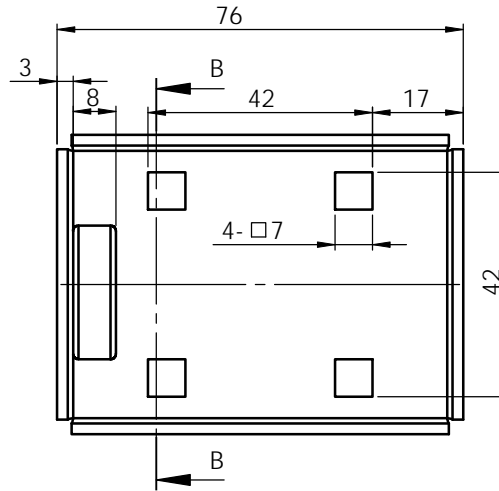
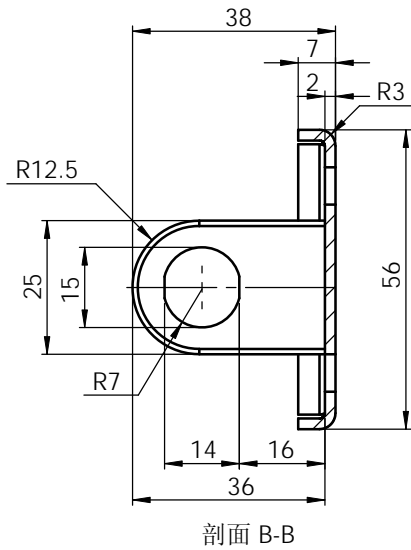

MATERIAL: MILD STEEL  
SURFACE FINISH: HOT DIP GALVANIZE

1	INITIAL	DRN	<b>BIRKDALE</b> Superior Gate and Fencing Accessories		
	ISSUE	DATE			
	1	CH'D	TITLE STRIKER BACK PLATE AND PAD		
		DATE	DRAWING No.	144 185 1-1,2	A3
		APP'D	WGT	SHEET OF SHEETS	

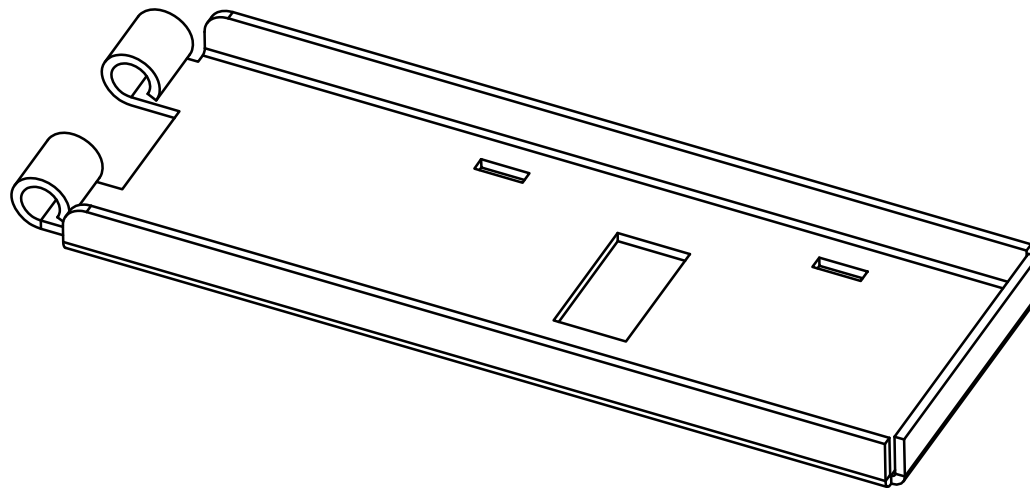
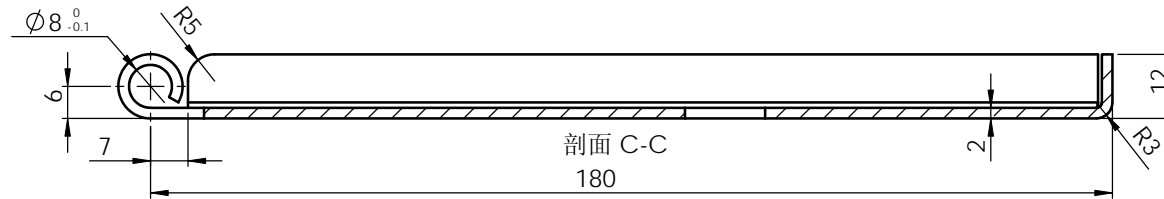
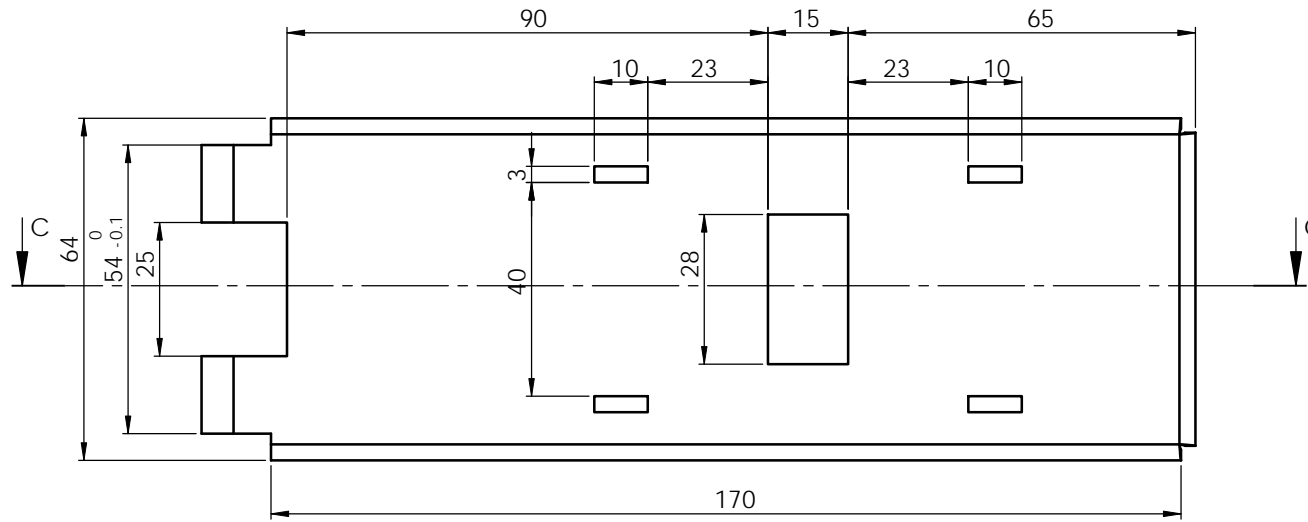

MATERIAL: MILD STEEL  
SURFACE FINISH: HOT DIP GALVANIZE

1	INITIAL ISSUE	DRN	<b>BIRKDALE</b> Superior Gate and Fencing Accessories		
	ISSUE	DATE			TITLE
		CH'D	FEMALE HINGE		
		DATE	DRAWING No.	1441851-3	A3
		APP'D	WGT	SHEET OF SHEETS	

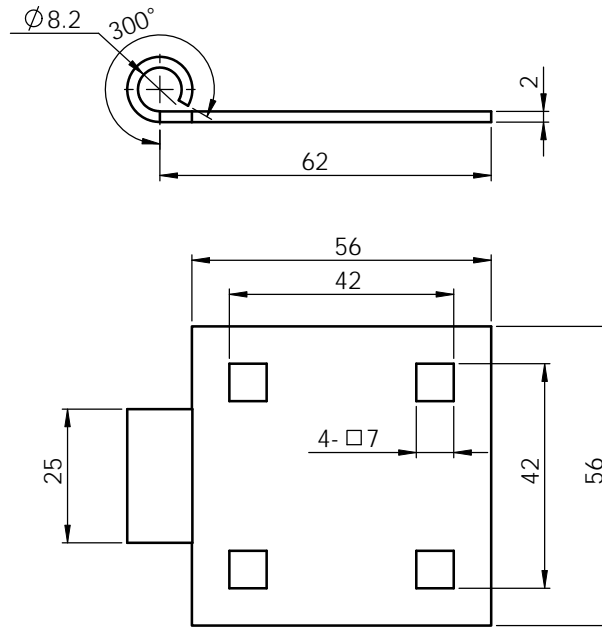

MATERIAL: MILD STEEL  
 SURFACE FINISH: HOT DIP GALVANIZE

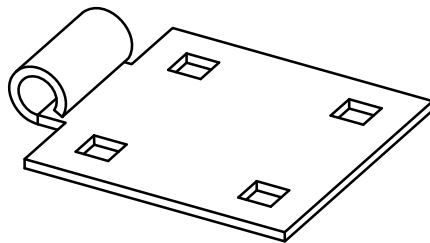

1	INITIAL	ISSUE	DRN	<b>BIRKDALE</b> Superior Gate and Fencing Accessories	
	DATE		TITLE		
			CH'D	MALE HINGE	
			DATE		
			APP'D	DRAWING No. 144 185 1-4	A3
			DATE	WGT	SHEET OF SHEETS

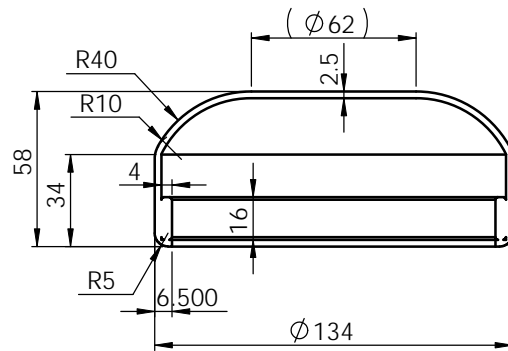
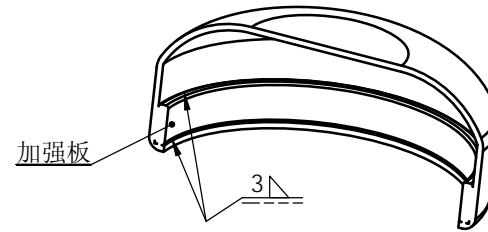
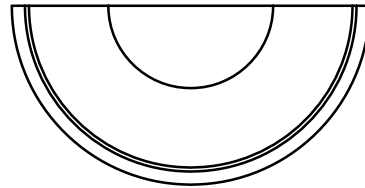

MATERIAL: MILD STEEL  
 SURFACE FINISH: HOT DIP GALVANIZE

1	INITIAL ISSUE	ISSUE	DRN	<b>BIRKDALE</b> Superior Gate and Fencing Accessories TITLE SHEILD	
			DATE		
			CH'D		
			DATE		
			APP'D		
DATE	WGT	SHEET OF SHEETS			

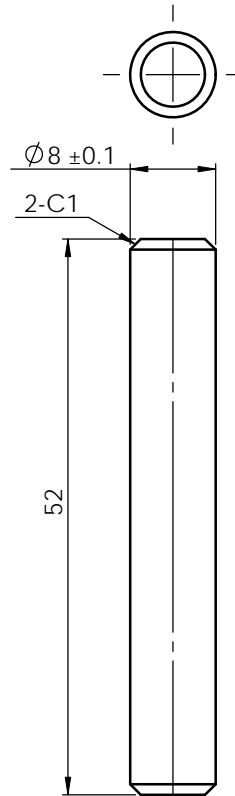

MATERIAL: MILD STEEL  
 SURFACE FINISH: HOT DIP GALVANIZE

1	INITIAL ISSUE	ISSUE	DRN	 Superior Gate and Fencing Accessories		
			DATE			
			CH'D			TITLE
			DATE			PIN
			APP'D			DRAWING No. 144 185 1-6
DATE	WGT	SHEET OF SHEETS				

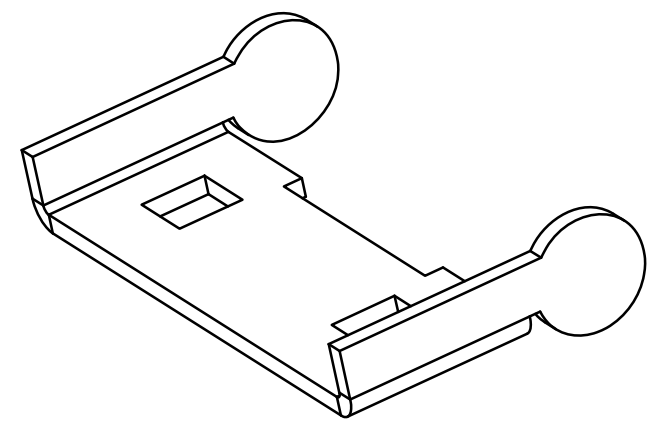
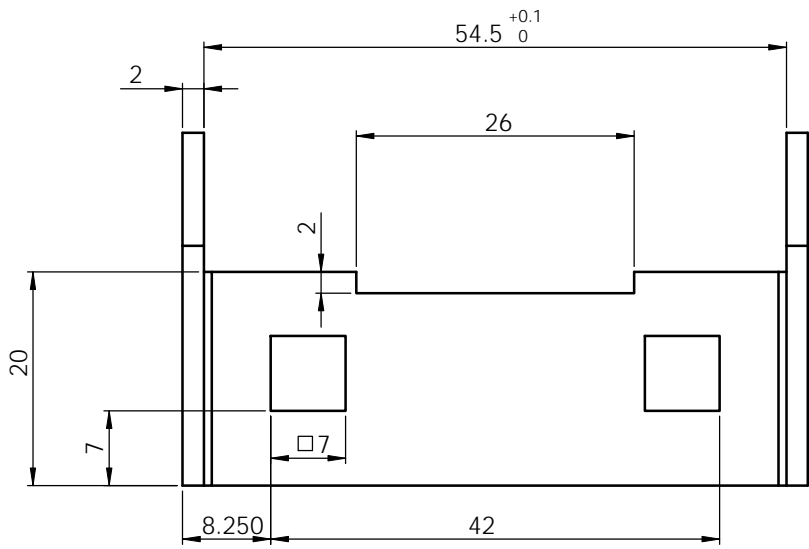

weight: 23g

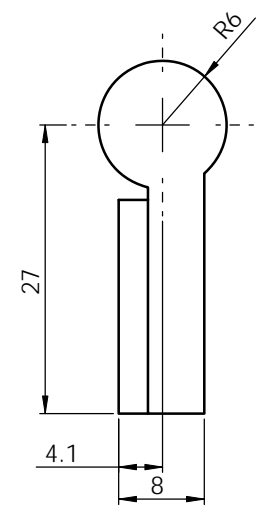

MATERIAL: MILD STEEL  
SURFACE FINISH: HOT DIP GALVANIZE

1	INITIAL ISSUE	ISSUE	DRN	 Superior Gate and Fencing Accessories TITLE SECURE PLATE	
			DATE		
			CH'D		
			DATE		
			APP'D		
DATE	WGT	SHEET OF SHEETS			